

RATING	GUN ORDERING PART NUMBER			GUN PLUG Direct Connect
260 Amp CO2 @ 60% Duty Cycle	750-26-010	w/ 180° Neck	10'	Euro Euro Euro
	750-26-015	w/ 180° Neck	15'	
200 Amp Mixed Gas @ 60% Duty Cycle	750-26-025	w/ 180° Neck	25'	Euro Euro Euro
	750-26-110	w/ 45° Neck	10'	
Wire Capacity: 0.023" (0.6mm) - 0.062" (1.6mm)	750-26-115	w/ 45° Neck	15'	Euro Euro Euro
	750-26-125	w/ 45° Neck	25'	

#	Part Number	Description
1.	165-52-001	Nozzle, Conical, 5/8" I.D., Std.
2.	165-52-002	Nozzle, Cylindrical, 3/4" I.D.
3.	165-52-011	Nozzle, Conical Small, 9/16" I.D.
4.	165-52-111	Nozzle, Conical Super Small, 7/16" I.D.
5.	150-06-120	Contact Tip, M6, .024" 0.6mm
	150-08-120	Contact Tip, M6, .030" 0.8mm
	150-09-120	Contact Tip, M6, .035" 0.9mm, Std.
	150-10-120	Contact Tip, M6, .040" 1.0mm
	150-12-120	Contact Tip, M6, .045" 1.2mm
	150-14-120	Contact Tip, M6, .052" 1.4mm
	150-16-120	Contact Tip, M6, 1/16" 1.6mm
6.	046-26-001	Insulator/Gas Diffuser, Std.
7.	160-06-026	Contact Tip Holder, M6, Std.
8.	160-06-126	Contact Tip Holder, Long, M6
9.	600-26-180	Swan Neck, 180°
10.	600-26-045	Swan Neck, 45°
11.	600-01-015	Wire Guide, 180° Swan Neck
12.	600-02-019	Wire Guide, 45° Swan Neck
13.	600-02-020	Teflon Liner, 45° Swan Neck
14.	600-60-002	Handle Complete (Includes items 14-17)
15.	600-03-002	Handle Screw, Top
16.	600-04-002	Handle Screw, Bottom
17.	600-04-022	Handle Nut, bottom
18.	170-14-002	Trigger Switch
19.	600-25-100	Gear Motor, 42V DC
20.	600-03-004	Gear Motor Screw
21.	600-08-035	Wire Drive Roll, .030" 0.8mm
	600-09-035	Wire Drive Roll, .035" 0.9mm
	600-10-035	Wire Drive Roll, .040" 1.0mm
	600-12-035	Wire Drive Roll, 3/64" 1.2mm/1.3mm
	600-14-035	Wire Drive Roll, .052" 1.4mm
	600-16-035	Wire Drive Roll, 1/16" 1.6mm
22.	600-20-035	Drive Roll Seat
23.	600-11-023	Washer for Drive Roll
24.	600-03-023	Screw, Drive Roll

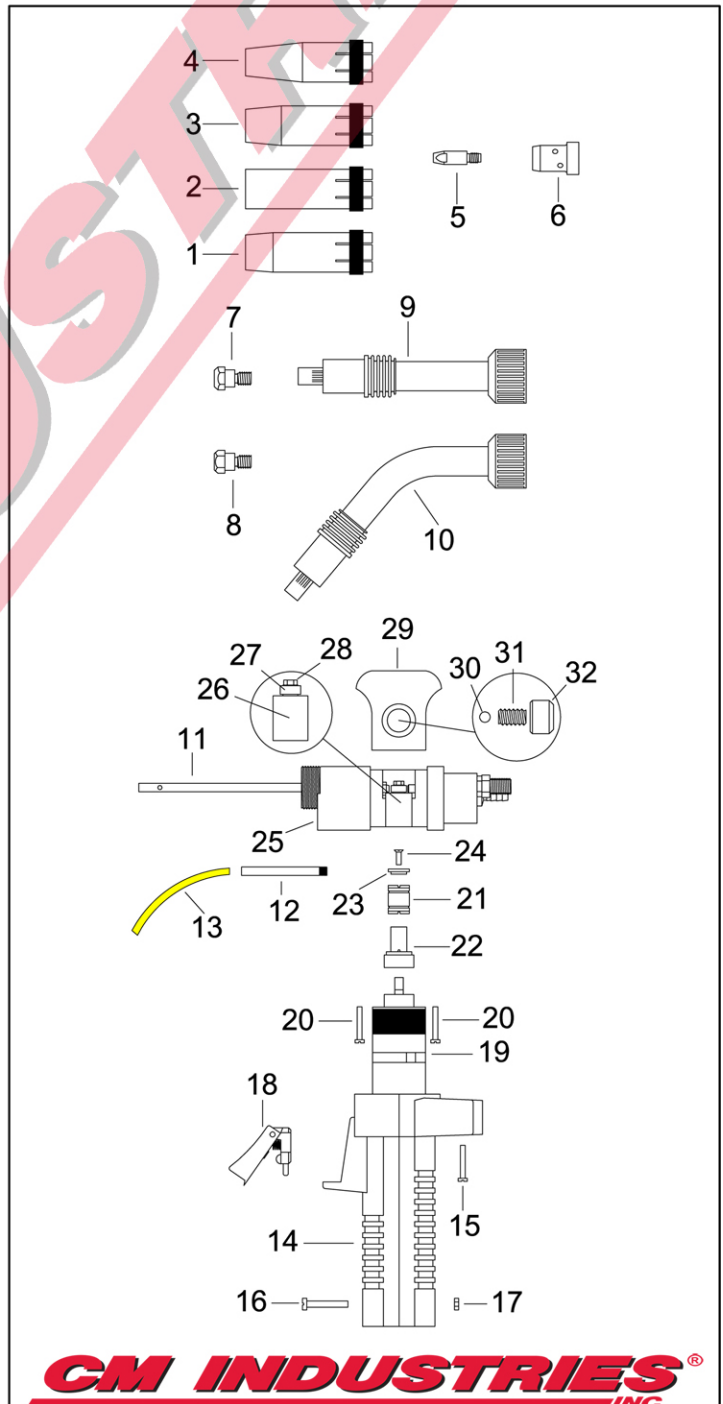

#	Part Number	Description
25.	600-26-122	Torch Body
26.	600-03-008	Idler Arm
27.	600-03-010	Idler Roll
28.	600-03-022	Hex Nut, Idler Arm
29.	600-03-009	Drive Roll Cap, w/ Hardware
30.	600-25-022	Ball, Drive Roll Cap
31.	600-25-023	Spring, Drive Roll Cap
32.	600-25-024	Knob, Drive Roll Cap
33.	300-05-009	Female Electrical Connector
34.	300-05-0__	Trigger Wire, 10', 15', 25'
35.	310-55-0__	Gas Hose, 10', 15', 25'
36.	350-60-095	Hose Clamp, 9.5mm
37.	600-20-009	Hex Adaptor
38.	600-30-0__	Power Cable, 10', 15', 25'
39.	600-20-005	Cable Support Screw
40.	600-20-006	Cable Support, Push-Pull
41.	260-52-001	Cable Support
42.	216-52-0__	Outer Cable Cover, 10', 15', 25'
43.	185-52-001	Cable Support Spring
44.	260-52-202	Adaptor Support
45.	285-01-001	Adaptor Support Screw
46.	300-05-010	Male Electrical Connector
47.	401-00-001	Adaptor Nut
48.	300-05-009	Female Electrical Connector
49.	401-02-114	Adaptor Block, PPA26
50.	285-03-002	Male Pin w/ Lead
51.	285-00-002	O-ring, Adaptor Block
52.	401-01-001	Liner Retaining Nut
53.	255-18-010	Teflon Liner #18, 10' .023"- .035"
	255-18-015	Teflon Liner #18, 15' .023"- .035"
	255-18-025	Teflon Liner #18, 25' .023"- .035"
	255-10-010	Teflon Liner #10, 10' .035"- .045"
	255-10-015	Teflon Liner #10, 15' .035"- .045"
	255-10-025	Teflon Liner #10, 25' .035"- .045"
	255-05-010	Teflon Liner #5, 10' .045"-1/16"
	255-05-015	Teflon Liner #5, 15' .045"-1/16"
	255-05-025	Teflon Liner #5, 25' .045"-1/16"
54.	259-10-001	Repl. Collet, Teflon Liner #10 & #18
	259-05-001	Repl. Collet, Teflon Liner #5

