

REPLACEMENT REAMERS

CM Industries Part Number	d=OD (mm)	d1=ID (mm)	Nozzle Size
651-09-07	9	7	3/8" - 10mm
651-10.5-08	10.5	8	7/16" - 11mm
651-12-09	12	9	1/2" - 13mm
651-12-10	12	10	1/2" - 13mm
651-12.5-09-19	12.5	9	1/2" - 13mm
651-12.5-09	12.5	9	1/2" - 13mm
651-12.5-10.5-19	12.5	10.5	1/2" - 13mm
651-13-09	13	9	14mm
651-14-09	14	9	9/16" - 15mm
651-14-11	14	11	9/16" - 15mm
651-15-09	15	9	5/8" - 16mm
651-15-11	15	11	5/8" - 16mm
651-15.5-13	15.5	13	5/8" - 16mm
651-17-11	17	11	11/16" - 18mm
651-18-11	18	11	3/4" - 19mm
651-18-13	18	13	3/4" - 19mm

Standard
1 Blade Reamers

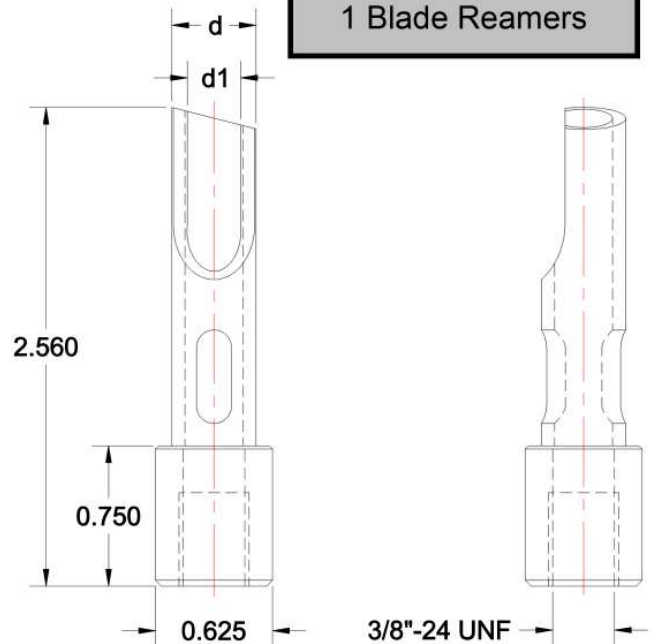

CM Industries Part Number	d=OD (mm)	d1=ID (mm)	Nozzle Size
652-09-07	9	7	3/8" - 10mm
652-11-07	11	7	7/16" - 11mm
652-12-09	12	9	1/2" - 13mm
652-12-10	12	10	1/2" - 13mm
652-12.5-09	12.5	9	1/2" - 13mm
652-12.5-10	12.5	10	1/2" - 13mm
652-13-09	13	9	14mm
652-14-09	14	9	9/16" - 15mm
652-14-11	14	11	9/16" - 15mm
652-15-09	15	9	5/8" - 16mm
652-15-11	15	11	5/8" - 16mm
652-15.5-13	15.5	13	5/8" - 16mm
652-17-11	17	11	11/16" - 18mm
652-18-11	18	11	3/4" - 19mm
652-18-13	18	13	3/4" - 19mm

Optional
2 Blade Reamers

